

TG V50

Dynamic Microphone



FEATURES

- Cardioid polar pattern
- Rugged construction
- Excellent transducer isolation
- TG V50 s version with on/off switch
- Supplied with microphone clamp and storage bag

APPLICATIONS

Whether in the rehearsal room or on a stage of any size, the dynamic TG V50 is an excellently tuned live vocal microphone. Especially notable are its balanced sound that is both powerful and natural, its very wide pick-up range thanks to its cardioid polar pattern, and its high feedback rejection; the whole product range is also outstanding in its handling, ruggedness, look and touch. The readiness of the TG V50 is also impressive – plug it in and it's ready. It is advantages like these that will win it many fans for use in lead and backing vocals of all music genres as well as by professional rental companies and sound technicians.

VERSIONS

- TG V50 Dynamic vocal microphone,
 cardioid incl. microphone clamp . . . Order # 707.252
- TG V50 s same as above, but with switch . . . Order # 707.260

TECHNICAL SPECIFICATIONS

- Transducer type Dynamic
- Operating principle Pressure gradient
- Polar pattern Cardioid
- Frequency response:
- Close miking 50 - 17,000 Hz
 - Distant miking (measured at 1 m) 80 - 17,000 Hz
- Open circuit voltage 2.4 mV/Pa (-52.5 dBV) \pm 3 dB
- Nominal impedance 600 Ω
- Load impedance \geq 2 k Ω
- Connection XLR, 3-pin, male
- Dimensions:
- Length 185 mm
 - Shaft diameter 23/35 mm
 - Head diameter 54 mm
- Weight 270 g

OPTIONAL ACCESSORIES

- MA-CL 29 Microphone clamp,
 3/8" and 5/8" Order # 727.911
- WS 59 AZ Wind shield, charcoal-grey Order # 419.087

TG V50

FREQUENCY RESPONSE & POLAR PATTERN

This polar pattern and frequency response curve (± 3 dB) correspond to a typical production sample for this microphone.

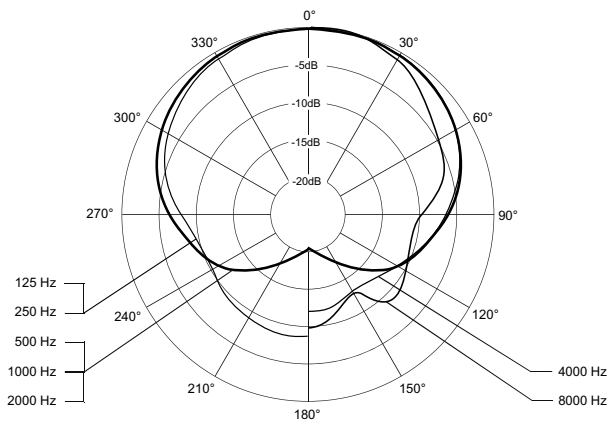
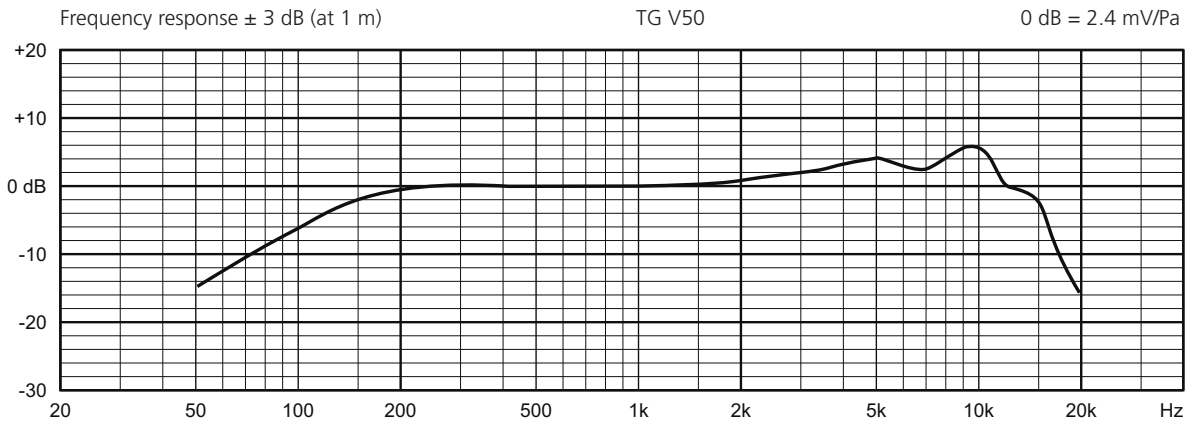

WIRING DIAGRAMS

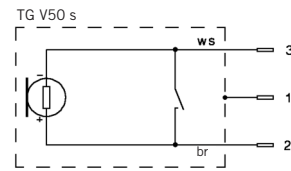
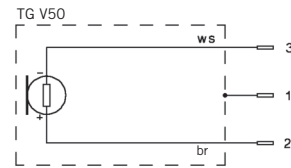

br = brown
ws = white